



kestrel
wind turbines

Registration Number 2006/005438/07

VAT Registration Number 4870231406

Tel: +27 (0)41 401 2500

Website: www.kestrelwind.co.za



e220

User Manual

Revision 1.3

(03-08)

Revision 1.2

(01-08)

Revision 1.1

(10-07)

Revision 1.0

(05-07)

CONTENTS

	PAGE
1 Safety Considerations	
1.1 Mechanical Safety	3
1.2 Electrical Safety	3
1.3 Installation Hazards	3
1.4 Operational Safety	3
2 Wind Turbine Overview	
2.1 Turbine Description	4
2.2 Identification and Markings	4
2.3 Applications and uses	5
3 Unpacking and Turbine Assembly	
3.1 Components Supplied	6
3.2 Tools Required	6
3.3 Unpacking	7
3.4 Technical Requirements for Assembly	7
3.5 Generator Assembly	7
3.6 Tail Assembly	8
3.7 Fitting the Pitch Control	8
3.8 Blade Assembly	9
4 Site Considerations and Mountings	
4.1 Mounting Flange Detail	10
4.2 Roof Mounting	10
4.3 Towers	10
5 Wiring and Cable Sizing	
5.1 Turbine Wiring	11
5.2 Lightning Protection	11
5.3 Wire and Cable Sizes	12
6 Battery Considerations	
6.1 Lead Acid Batteries	13
6.2 Sealed Gel Batteries	13
6.3 Ni-Cad Batteries	13
6.4 Temperature Compensation	13
7 Technical Details	
7.1 Technical Specification	14
7.2 Declaration of Conformity	14
8 Trouble shooting	15
9 Maintenance	16
10 Customer Feedback	23

Disclaimer

Kestrel Wind Turbines makes every effort to give accurate information in this manual and is in no way liable for any error or omission. The user of this manual assumes full responsibility and risk.

We appeal to your common sense to read and apply the safety notes. Consult professional engineers and take advice if you are unsure.

1 SAFETY FIRST

1	Safety Considerations
1.1	Mechanical Safety
1.2	Electrical Safety
1.3	Installation Hazards
1.4	Operational Safety

Although Kestrel's wind turbines are designed with your safety in mind, accidents can easily occur and there are always inherent dangers associated with any type of machine. **Consult installation professionals if you lack experience or confidence.**

1.1 Mechanical Safety

Use good handling methods and take precautions to avoid physical injury during installation and maintenance/repair procedures. The rotating blades of any wind turbine are a main hazard. The e220 blades are extremely tough and will cause serious injury to the body. **Never install the e220 such that any person or animal could come into accidental contact with any part of the machine. Never approach the machine if the blades are rotating.**

1.2 Electrical Safety

The e220 output voltage can become dangerous and even lethal when running on open circuit. Maintain a healthy respect for this wind turbine. **Always short the output wires together when the e220 is disconnected. Do not work on the system when the turbine is running or when lightning is possible.** Disconnecting a running e220 may cause a spark and the presence of explosive hydrogen from battery charging is always a possibility. **Adequate ventilation must be provided for battery installations.** The wire size used for connections must be correct for the powers supplied. The smaller the wire diameter, the higher the wire losses and therefore the heat generated in the wire. **Use correct wire sizes throughout the installation.** The amount of energy stored in a battery is considerable and fire can result from shorts. **Fit a suitable fuse or circuit breaker in the battery cable. In general, respect the system and use common sense. Consult a qualified electrician if you are unsure.**

1.3 Installation Hazards

All installation work should be completed at ground level wherever possible. Be very aware of the blades during installation. Contact with the blades will only injure you, not the blades. The installations of poles or towers pose their own dangers. Always work carefully and have an assistant wherever possible. **Short the generator output wires (Red and Black) throughout any installation procedure.** Consult a civil engineer or reputable builder if you are not sure about installing structures. Always re-check the work as you progress. Slack bolts, poor workmanship and loose electrical connections must be avoided.

1.4 Operational Safety

The turbine blades are dangerous. **Respect a rotating turbine.** Always shut the turbine down before approaching. This may be achieved by shorting the generator output. **Preventative maintenance is always the best.** Checks are best carried out in calm weather conditions. Avoid any maintenance or inspection during windy weather.

2 WIND TURBINE OVERVIEW

2 Wind Turbine Overview

- 2.1 Turbine Description
- 2.2 Identification and Markings
- 2.3 Application and Uses
 - 2.3.1 Charge Controllers and Inverters
 - 2.3.2 Grid Tied Inverter Applications
 - 2.3.3 Voltage Limiter

2.1 Turbine Description

The e220 is a unique wind turbine that incorporates superior technology. The heart of the machine comprises of a single axial flux permanent magnet brushless alternator. The alternator contains no less than 48 poles and 26 magnets. The polyphase high frequency output is internally rectified to give a dc output with extremely low ripple content. The generated power is transferred to the output cables via heavy duty bronze slip rings and twin copper composite electrical brushes. The prime mover on the e220 is a 2.2m (7.2') diameter three blade wind rotor fitted with quiet running high efficiency blades. The blade hub incorporates pitch control. The e220 pitch control rotates the blades to achieve speed control in high wind. The tail vane assembly is static and simply aligns the machine with the prevailing wind.

All steel components are electro-galvanised and passivated for extra protection. The standard finish consists of the application of an etching marine primer and an intermediate protective coat followed by polyurethane two pack finishing coats.

2.2 Identification and Markings

The turbine generator body carries a stamped unique serial number and a rating plate. Both the stamped serial number and rating plate are visible on the bottom yaw shaft housing. If this e220 does not carry this stamp it does not carry a Kestrel warranty and may not be authentic.

kestrrel wind turbines			
PRODUCT RATING LABEL			
TYPE	0501	SWT Class No.	II
VOLTAGE	200 Vdc	ROTOR DIAMETER	2,2 m
CURRENT	3,5 Adc	SWEPT AREA	3,8 m ²
RATED POWER	800 Wdc	MANUFACTURED	Nov06
SERIAL NUMBER	0611044-500		
MADE IN SOUTH AFRICA BY	Eveready Diversified Products (Pty) Ltd T/A Kestrel Wind Turbines P.O. Box 3191, Struandale, North End Port Elizabeth, 6056 RSA		

2.3 Applications and Uses

The e220 is suitable for electrical power generation on various installations that include battery charging, water delivery and grid tie applications. Each application requires specific additional electrical equipment. Consult the manuals supplied with this equipment.

2.3.1 Charge Controllers and Inverters

Any wind turbine produces uncontrolled power that varies with incident wind speed. The open circuit generator voltage is directly proportional to generator speed (rpm). Some form of regulator must control this “raw power”. A battery charging regulator is often referred to as a charge controller. A charge controller is required for the Kestrel to charge a battery. Kestrel can supply a standard charge controller for the e220. A suitable load resistor is available from Kestrel.

An Inverter can be connected to the battery and is used to convert the battery dc power to ac power. An inverter therefore allows the use of standard electrical equipment that works on ac voltage.

2.3.2 Grid Tied Inverter Applications

The 200Vdc version of the e220 is suitable for connection to an approved Grid Tie Inverter. Grid Tied installation is subject to local electrical codes of practice and is usually carried out by qualified personnel. Prior approval from the local utility company must be obtained before connection to the mains.

2.3.3 Voltage Limiter

Grid tied applications require a Voltage Limiter to be connected between the e220 (200Vdc version) and the Grid Tie Inverter. Certain operating modes of the inverter allow the Kestrel output voltage to rise beyond the limit of the inverter. The Kestrel Voltage Limiter will restrict the rise in voltage as the inverter performs various functions. Refer to the manual provided with the Kestrel Voltage Limiter.

3 UNPACKING AND TURBINE ASSEMBLY

3.1 Components Supplied

The following components are supplied.

- Pitch hub assembly
- Shaft drive key
- Propeller blade set
- Generator assembly
- Tail boom
- Tail
- Nacelle cover
- Nosecone
- Assembly grease

3 Unpacking and Turbine Assembly

- 3.1 Components Supplied
- 3.2 Tools Required
- 3.3 Unpacking
- 3.4 Technical Requirements for Assembly
- 3.5 Generator Assembly
- 3.6 Tail Assembly
- 3.7 Fitting the Pitch Control
- 3.8 Blade Assembly

3.2 Tools Required

The following hand tools are required for turbine assembly and installation.

- 10mm metric ring spanner or socket wrench (two required)
- 13mm Metric ring spanner or socket wrench
- 16mm Metric ring spanner or socket wrench
- Small size electrical screwdriver
- Medium size electrical screwdriver
- 10mm Allen key
- Wire strippers for electrical connections
- Tape measure to adjust the blades

3.3 Unpacking

Open the packaging container and check for any transit damage. The parts contained are listed in section 3.1 and on the included packing slip. Lay out the parts and identify them with the assembly drawing provided.

PART No.	DESCRIPTION	QUANTITY
0500/1510	GENERATOR ASSEMBLY	1
0602/0520	TAIL	1
0602/0520	TAIL BOLT	4
0602/0520	TAIL BOLT NUT	4
0602/0520	TAIL BOLT WASHER	4
0602/0520	TAIL BOOM ASSEMBLY	1
0602/0520	TAIL BOOM BOLT	4
0602/0520	TAIL BOOM NUT	4
0602/0520	TAIL BOOM WASHER	4
0602/0520	SHAFT KEY	1
0602/0520	PITCH BOSS	1
0602/0520	BLADE MOUNT	3
0602/0520	COMPRESSION PLATE	3
0602/0520	BLADE BOLT	9
0602/0520	BLADE NUT	9

PART No.	DESCRIPTION	QUANTITY
0602/1630	BLADE WASHER	3
0602/1660	PROPELLER BLADE	3
0602/1670	PITCH SHAFT	3
0602/1680	OUTER WASHER	3
0602/1690	PITCH BEARING	3
0602/1710	BEARINGS SPACER	3
0602/1710	INNER WASHER	3
0602/1720	OUTER WEIGHT	3
0602/1730	NACELLE	1
0602/0740	NACELLE SCREW	3
0602/0750	NACELLE WASHER	3
0602/1760	INNER WEIGHT BOLT	3
0602/1770	INNER WEIGHT WASHER	3
0602/1780	LEVER	3
0602/1790	LEVER PIN	3

PART No.	DESCRIPTION	QUANTITY
0502/0801	LEVER PIN NUT	6
0502/0801	LEVER PIN WASHER	6
0502/0820	SYNCHRO BOLDER	1
0502/0830	FRONT WASHER	1
0502/0840	PROP SHAFT BOLT	1
0502/0850	SYNCHRO SHAFT	1
0502/0860	RETURN SPRING	1
0502/0870	GRUB SCREW	1
0502/0880	ANTI RATTLE RUBBER	1
0502/0890	OUTER WEIGHT BOLT	6
0502/0901	LEVER SPACER	3
0502/0910	INNER WEIGHT	3
0502/0920	NOSE CONE	1
0502/0930	NOSE CONE SCREW	6
0502/0940	NOSE CONE WASHER	6
0502/0950	NOSE CONE PLATE	1
0502/0960	NOSE CONE PLATE BOLT	3
0502/0970	NOSE CONE PLATE NUT	3
0501/0720	LABEL (WARNING PLATE)	1
0501/0730	LABEL (WARNING MECH)	1
0501/0740	LABEL (TAIL BECAL)	2
0501/0810	LUBRICATION GREASE	1

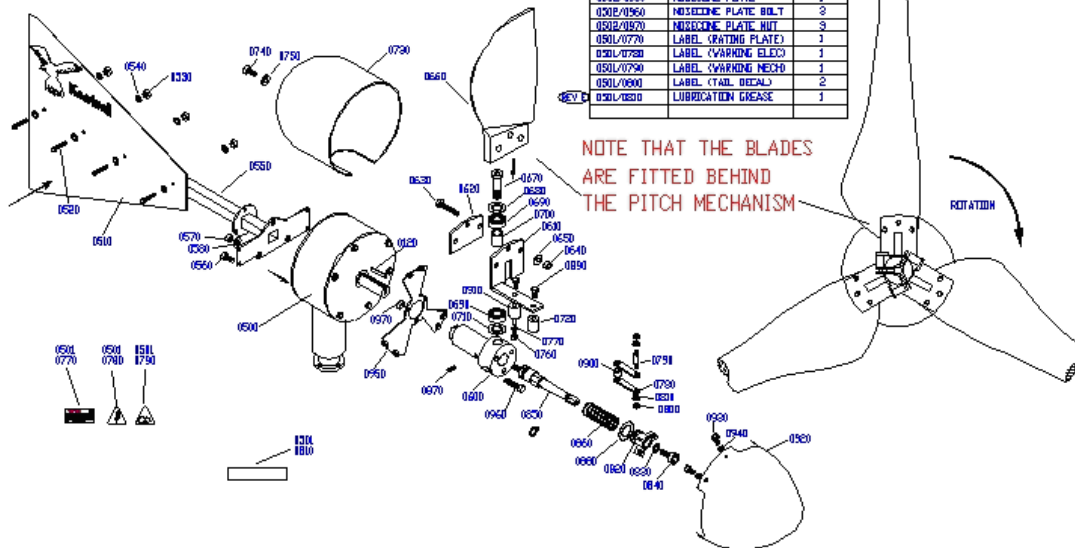

3.4 Technical Requirements for Assembly

Torque Settings

DESCRIPTION	BOLT TYPE	TORQUE (Metric)	TORQUE (Imperial)
NOSE CONE SCREWS	M6 x 16, S/S	5Nm	3,7 ft·lb
FRONT BOLT	M10 x 20 ALLEN CAP SCREW	30Nm	22,2 ft·lb
BLADE BOLT	M10 x 70, S/S WITH M10 NYLOCK NUT	35Nm	25,8 ft·lb
TAIL BOOM	M6 BOLTS, S/S	15Nm	11,1 ft·lb
	M8 NYLOCKS	25Nm	18,4 ft·lb
SECURING SCREW	M8 x 10, S/S GRUB SCREW	15Nm	11,1 ft·lb
NACELLE SCREWS	M5 x 15, S/S	3Nm	2,2 ft·lb
TAIL BOLTS	M6 x 40, S/S WITH M6 NYLOCK NUT	10Nm	7,4 ft·lb
MOUNTING BOLTS	M8 x 25, 8.8 HI-TENSIL PLATED	35Nm	25,8 ft·lb
SYNCHRO SHAFT	M10	50Nm	37,0 ft·lb



3.5 Generator Assembly

The alternator (0500) is factory assembled.

3.6 Tail Assembly

Offer the tail boom (0550) to the rear of the generator and align the three inner fixing holes with the inner studs. Fasten the boom to the rear of the generator with the three M8 Nylock nuts (0570). Now fit the four outer M6 bolts (0560) into the generator rear and tighten all fastenings.

Slide the nacelle (0730) up the boom and fasten so that it is covering the generator.

Fasten the tail plate (0510) to the boom with the four stainless bolts (0520) and four stainless flat washers (0540) with the four stainless Nylock nuts (0530) provided.



Do not over-tighten such that the tail boom is crushed or distorted. Check once again that all bolts are fitted and tighten to torque settings in section 3.4.

3.7 Fitting the Pitch Control

The generator is a complete unit. The shaft drive key is factory fitted to the generator shaft with a cable-tie. Remove cable-tie, before fitting pitch control.



Smear waterproof grease over the shaft and insert a little inside the front of the generator where the shaft projects out.



Offer the pitch control hub to the shaft after removing the M8 grub screw (0870) and slide it on.

Using an M16 ring spanner, thread the centre syncro shaft (0850) into the hub and tighten the assembly. Now fit and tighten the side M8 grub screw (0870) in the pitch boss (0600). This grub screw locks the syncro shaft. Lastly, fit the stainless cap and front shaft M10 Allen bolt. See 3.4 for torque settings.

It is important that the bolt is secured with Loctite.



3.8 Blade Assembly e220

IMPORTANT: The wheels of a car are balanced to allow smooth operation. In the same way, the propeller rotor must be assembled such that it is balanced. Rotor imbalance will cause vibration, unstable operation of the turbine and eventual damage.

NOTE: The blades are fitted behind the blade mounts (between the blade mounts and the generator). Refer to the assembly drawing and fit all three blades on to the hub as shown. Each



blade carries a serial number and a balance mark on the front face of the blade. Be sure to fit the blades the correct way round. The concave surface, serial number and balance mark all face forward. The rotation is clockwise viewed at the front of the turbine. Each blade mount has three bolt holes. Fit the bolts with the Nylock nuts forward such that the nuts will be covered by the nose cone.

The blades are factory balanced. Note that exact balancing requires that the three blade tips be equally spaced when fitted. Please follow the instructions given below.

a) Support the generator (0500) such that the blades can be fitted to the blade mounts (0610).

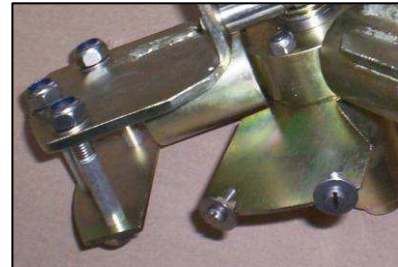

b) Fit three blade bolts (0630) through a blade compression plate (0620) such that they face forward. Now fit the first blade (0660) on to the bolts and offer the blade **from behind** to the blade mount (0610). Fit the three Nylock nuts (0640) on to the blade bolts from the front. Do not tighten the nuts.



c) Repeat (b) such that all three blades are sandwiched between the three compression plates (0620) and the three blade mounts (0610). Now gently tighten all nine blade bolts such that each blade can still move sideways.

d) Using a tape measure, measure the distance between each of the three blade tips. Move each blade sideways until all three blade tips have the same measured distance between them. If the blades carry a balance point mark, position the blades until the distance between the balance marks are all equal by measurement.



e) Now tighten all the blade bolts (refer to 3.4 Torque Settings). Do not over-tighten the bolts such that any blade is damaged or crushed.

f) Check the assembly for correctness. Check the blades are fitted correctly, the bolts are all tightened and that the rotor spins freely and evenly on the generator. Check the distance between the three blade tips (or balance marks) to be equal.



g) Now slide the nose cone (0920) over the blade hub and fit the six retaining screws (0930) and washers (0940).

4 SITE CONSIDERATIONS AND MOUNTING

4 Site Considerations and Mounting

4.1 Flange Mounting Detail

4.2 Roof Mounting

4.3 Towers

The turbine is supplied with a “weld on” mounting flange for adaptation. There are infinite variations on sites and the information and suggestions may be adapted to suit local conditions. Wind speed increases with height above the ground. An installation site should be chosen which is free of obstructions like buildings, trees, mounds and hills. A “pure” airflow is paramount for good performance. Naturally some compromise can be reached but there should be a clear entry for the prevailing wind direction of the location. The absolute minimum height of the structure should be 6m when placed clear of obstructions.

The general rule is that the e220 should be 8m (25’) higher than any obstruction within a 150m (500’) radius of the tower. Otherwise mount the e220 as high as possible. All obstructions add to possible turbulence, which will cause undue stress on the unit and reduced performance. Wind speed increases with height above the ground. The power in the wind is a cubic function of wind speed. Doubling the wind speed increases the power by eight times.

4.1 Flange Mounting Detail

The e220 is mounted using four M8 Hi-Tensile Stainless bolts and spring washers fitted through the bottom flange on the weather cocking swivel assembly.

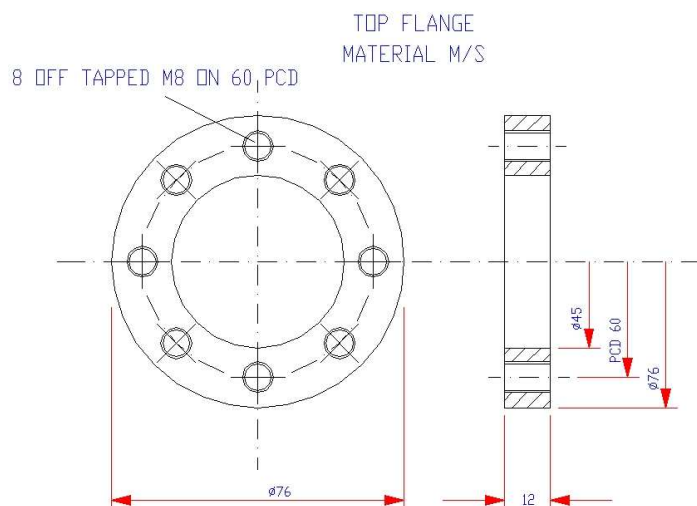

Four bolts are supplied for mounting of the e220 unit, however eight holes have been provided to allow interchange-ability between all Kestrel units. Secure the assembled e220 unit by using holes 1, 3, 5 and 7 as shown along side, and the M8 Hi-Tensile bolts with spring washers.

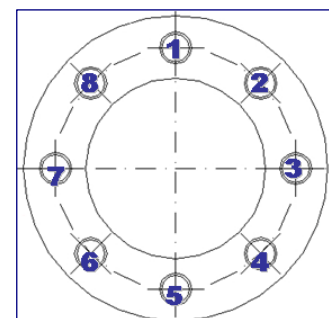

4.2 Roof Mounting

Roof mounting is possible but the turbine performance may suffer as a result of wind shift and turbulence. Roof mounting structures are beyond the scope of this document and must comply with the relevant structural standards that are in force.

4.3 Towers

Towers are required to conform to relevant standards and must be designed to withstand the loading regime of the wind turbine. Full details are included with any Kestrel tower kit supplied.

5 WIRE AND CABLE SIZES

5	Wiring and Cable Sizes
5.1	Turbine Wiring
5.2	Lightning Protection
5.3	Wire and Cable Sizes

5.1 Turbine Wiring

The e220 wind turbine produces dc power and therefore has two double insulated output wires (tails). The RED wire is POSITIVE and the BLACK wire is NEGATIVE.

Observe the Polarity at all times. Only connect +VE RED cables to +VE RED terminals and -VE BLACK cables to -VE BLACK terminals. Otherwise, equipment damage may result and any warranty will be invalidated.

The following suggestions are made as a guideline. If you are in doubt, consult an electrician.

The output wires must be extended as required for the installation. Good wire connections are absolutely essential to avoid poor power delivery and high temperatures at the connection.

All electrical systems lose energy because cables have a resistance. The mounting structure must be directly earthed for lightning. The power cable is usually brought down the inside of the mounting structure to give some protection. Supply cables should never be spanned or suspended from the turbine structure and should be buried at least one half metre deep in a suitable plastic or steel conduit.

5.2 Lightning protection

Proper grounding is essential to protect the system from induced voltages and static. Local requirements for electrical installations must be satisfied. Ensure that the generator is electrically connected to the mounting structure and that the structure is earthed. This is usually done by burying a 2 to 3m (6' – 10') length of water pipe (Steel or copper) horizontally, 800mm (2.5') below the ground surface. A good connection is made between the middle of the pipe and the structure. An improved method is to bury a cross of pipe, which requires a "X" shape to be excavated. The connection is made in the centre of the cross.

The negative battery connection should also be grounded using a ground point close to the battery. First, consult the Charge Controller Manual to avoid earth loos. The wire size for grounding should be the same size as the power cables. Commercial lightning arrestors are available at electrical stores and can be fitted at the bottom of the structure or pole or at the regulator input.

5.3 Wire and Cable Sizes

The copper wire sizes given in the tables are calculated for 3% power loss in wire resistance. This is usually acceptable in low voltage installations. A larger wire size will increase the delivered power but usually a compromise is reached as larger cables cost more. It is recommended that the wire sizes given be taken as a minimum value.

Measure the distance from the top of your structure (i.e. the e220) to the regulator. Select the wire size for that distance from the table. The double run of +ve and -ve is already accounted for.

The power cable should be run down the inside of the pole or structure and then buried in a suitable underground conduit at least 500mm below the ground surface.

Wire Size for 12V e220 (60A maximum current)

10m (33')	20m (66')	30m (96')
35sq mm (2)	45sq mm (1)	85sq mm (000)

Wire Size for 24V e220 (32A maximum current)

10m (33')	20m (66')	30m (96')	40m (130')	50m (165')
16sq mm (5)	35sq mm (2)	50sq mm (0)	70 sq mm (00)	95 sq mm(0000)

Wire Size for 48V e220 (19A maximum current)

10m (33')	20m (66')	30m (96')	40m (130')	50m (165')	80m(260')	100m (330')
10sq mm (7)	20sq mm (4)	35sq mm (2)	35sq mm (1)	50sq mm (0)	70sq mm (00)	100sqmm(0000)

Wire Size for 200V e220 (4A maximum current)

20m (66')	40m (130')	60m (200')	80m(260')	100m (330')
0,5sq mm (20)	0,8sq mm (18)	1,5sq mm (16)	1,5sq mm (16)	2,0sq mm(14)

6 BATTERY CONSIDERATIONS

6 Battery Considerations
6.1 Lead Acid Batteries
6.2 Sealed Gel Batteries
6.3 Ni-Cad Batteries
6.4 Temperature Compensation

Batteries are available in many shapes, sizes and chemistry. Battery dealers will be pleased to assist. The most common ones are reviewed below. In general, only "Deep cycle" batteries and cells should be used and automotive or vehicle batteries will have a short life as they are not designed for cyclic charging and discharging. A cell is a single unit of 2V and a battery consists of a number of cells joined in series. The usual installation consists of 12V batteries arranged in series or parallel, or both. Batteries should not be exposed to temperature extremes and good ventilation is required as batteries can emit hydrogen while being charged.

The stored energy in a battery is given in Ampere Hours (Ah) or Watt hours (Wh). The capacity is often based on a 10 hour discharge rate. A 100Ah battery will therefore supply a current of 5A for 20hrs or 10A for 10hrs or 20A of current for 5hrs. It will not however supply 100A of current for 1hr. There is much literature available on this subject. It is recommended that the e220 should be charging at least 200Ah of battery capacity for a 12V system.

6.1 Lead Acid Batteries.

These are the most popular choice of battery type and can be vented/flooded (Water may be added), or semi-sealed or low maintenance (Water cannot be added). Charging voltage is typically 13.8-14.0 / 27.6-28.0Vdc for these batteries.

6.2 Sealed Gel Batteries

Sealed gel batteries are more expensive but offer clean and safer operation as no acid can be spilled. Since they are sealed, they must never be boosted and the charging voltage is important. Charging voltage is typically 14.0 / 28.0Vdc. Consult your battery supplier.

6.3 Ni-Cad Batteries

This type of battery is traditionally used where large currents must be delivered and where deep cycling is required. They are however relatively expensive. Consult your battery supplier for details.

6.4 Temperature Compensation

Much has been documented on this subject and there are certain merits. Generally, lower and higher ambient temperatures allow higher and lower charging voltages respectively. Batteries should be sited in a cool area and temperature compensation is only useful in extreme temperature variations.

7 TECHNICAL SPECIFICATIONS

7 Technical Details
7.1 Technical Specifications
7.2 Declaration of Conformity

7.1 TECHNICAL SPECIFICATIONS

e220

Maximum Power	850W
Rated power at 11m/s 200Vdc	700W
Rated power at 11m/s 48Vdc	690W
Rated power at 11m/s 24Vdc	600W
Rated power at 11m/s 12Vdc	550W
Annual energy capture at 5m/s average 200Vdc	1100kWh
Annual energy capture at 5m/s average 48Vdc	1000kWh
Annual energy capture at 5m/s average 24Vdc	870kWh
Annual energy capture at 5m/s average 12Vdc	800kWh
	<small>(For average wind speed of 5ms⁻¹ and 12m tower at sea level)</small>
Rated sound level	<50dB
Cut-in wind speed	2,5ms⁻¹
Cut-out wind speed	N/A
Maximum voltage 200Vdc	1000Vdc
Maximum voltage 48Vdc	250Vdc
Maximum voltage 24Vdc	150Vdc
Maximum voltage 12Vdc	70Vdc
Output power form	Two wire DC
Rotor swept area	3,80 sq m
No. of blades	3
Tower top mass	45kg
Lateral Thrust at 12ms⁻¹ (27mph) and 40ms⁻¹ (90mph)*	350N and 3900N
	<small>*NOTE: Lateral Thrust at 40ms⁻¹ is theoretical for a failed pitch control. For normal operation, thrust at 40ms⁻¹ is <1000N</small>
Speed Control	Passive pitch
Protection	IP55

7.2 DECLARATION OF CONFORMITY

Declaration of Conformity

Eveready Diversified Products (Pty) Ltd T/A
Kestrel Wind Turbines

in South Africa

declare under our sole responsibility that the product

 Wind Turbine

To which this declaration relates is in conformity with the following standards

IEC 60038	Rotating Electrical Machines
IEC 60204-1	Safety of Machinery
IEC 60038	IEC Standard Voltages
IEC 60529	Degrees of Protection of Enclosures
IEC 61000	Electromagnetic Compatibility

and follows the provisions in the directives

IEC61400-2 (Small wind Turbines)

Date: 11th December 2006

Place: Port Elizabeth South Africa

Authorising Signature:



James Carpy
Technical Director

Kestrel Wind Turbines
P O Box 3191
North End
Port Elizabeth
6056
Republic of South Africa

8 TROUBLE SHOOTING

REST ASSURED THAT THE KESTREL WILL BE SERIOUSLY DAMAGED FROM POLARITY REVERSAL. OVERCHARGING OF THE BATTERY CAN OCCUR WITH NO FITTED CHARGE CONTROLLER. IT IS UNWISE TO DISCONTINUE CHARGING BY DISCONNECTING THE e220 FROM THE BATTERY. THE TURBINE THEN HAS NO LOAD WHATSOEVER AND CAN REACH VERY HIGH ROTATIONAL SPEEDS.

Uncontrolled output voltage can reach LETHAL values.

IF THE e220 IS DISCONNECTED FOR ANY REASON, SHORT THE GENERATOR OUTPUT WIRES. THIS WILL LOAD THE GENERATOR AND MINIMISE ROTATION.

DO NOT ALLOW THE e220 TO OPERATE WITH DAMAGED BLADES OR TAIL. DAMAGE TO THE BLADES WILL CAUSE VIBRATION THAT CAN INCREASE TO DESTRUCTIVE LEVELS.

DO NOT ALLOW THE e220 TO OPERATE WITH ANY SIGN OF UNBALANCE. ANY REPETITIVE SWINGING OF THE TAIL INDICATES THAT THE MACHINE IS UNBALANCED.

- Q There is wind but the e220 does not rotate or only rotates very slowly.
- A The e220 output is shorted. There is an electrical short elsewhere in the system. The blades are fitted the wrong way round. The e220 is restricted from swinging 360 degrees into the wind. The charge controller is defective. Other connected equipment is defective. (Disconnect the e220 from the equipment and check that the blades rotate easily). There is a short within the turbine generator. In very light wind, the e220 may well not rotate. This is quite normal as there is no useful power in such a light wind and bearing life is greatly extended. On older machines, check the generator bearings.
- Q The e220 is rocking from one side to the other at low speed but appears to run smoothly at higher speeds.
- A The blade rotor assembly is unbalanced. Remove the rotor and check for damaged blades. Rebalance the rotor if possible or fit a new blade set.
- Q The e220 is vibrating or noisy.
- A Check all fasteners on the unit, in particular the blade assembly. Vibration or noise can only be caused by the imbalance of damaged blades. Check for bearing wear on older machines.
- Q Can the e220 be left running and disconnected?
- A Theoretically yes, but high voltages may be produced. Always short the output wires when the e220 is disconnected from the regulator.
- Q What should be done in storm conditions?
- A Never approach the e220 during strong wind conditions. The e220 has been tested up to winds of 160km/h and is designed to survive such conditions. It is acceptable to lower the turbine for predicted extreme weather conditions simply for peace of mind.

9 MAINTENANCE

9 Maintenance
9.1 Biannual Checklist
9.2 Maintenance Schedule
9.3 Other Details

9.1 BINANNUAL CHECKLIST

The e220 is designed for continuous operation on 100% duty cycle and requires no regular part replacement. It is recommended that preventative maintenance checks be carried out every six months and after the occurrence of extreme weather.

NEVER APPROACH A ROTATING TURBINE

- a) Inspect the tower or pole including all bolts/fasteners ground anchors and guy wires.
- b) Inspect the blades for any damage. Check the blade fixing bolts.
- c) Inspect the e220 securing bolts.
- d) Check the tail assembly and fixing bolts for damage. Replace if required.
- e) Wash the blades with clean soap and water.
- f) Check the blades for any wear or erosion.
- g) Check all electrical connections for tightness and corrosion.
- h) Check that the passive pitch mechanism is functional.

9.2 MAINTENANCE SCHEDULE

The e220 is designed to operate with minimum maintenance. The frequency of visual inspections and integrity checks depends on the wind class of the installation site. Wind Power Class definition for wind power density and average wind speed at a hub height of 10m is given below. In general, higher class wind sites require more frequent installation checks.

Wind Power Class	Wind Power Density (W/sq m)	Wind Speed m/s	Wind Speed mph (Imperial)
1	Up to 100	Up to 4,4	Up to 9,8
2	100 – 150	4,4 – 5,1	9,8 – 11,4
3	150 – 200	5,1 – 5,6	11,4 – 12,5
4	200 – 250	5,6 – 6,0	12,5 – 13,4
5	250 – 300	6,0 – 6,4	13,4 – 14,3
6	300 – 400	6,4 – 7,0	14,3 – 15,7
7	Above 400	Above 7,0	Above 15,7

The following schedule is designed to avoid machine failure. Component life will be reduced on sites that exhibit high turbulence.

Wind Power Class	1	2	3	4	5	6	7
First post installation visual check	All sites 1 month after installation						
Visual Inspection, listen for abnormal noise and vibrations.	After extreme weather and every 3 months			After extreme weather and every 2 months			
Close inspection, check for any loose bolts, blade damage. Check proper operation of pitch control. Touch up paint.	12 monthly intervals				Six monthly intervals		
Dismount the machine and check for transfer brush wear. Check for wear on pitch control parts. Replace as required. Treat any corrosion and touch up paint.	Every 5 years			Every 3 years			
Dismount the machine and replace all bearings (generator, yaw shaft and pitch control)	Every 8 – 10 years			Every 4 – 5 years			

Maintenance Tips

The generator produces a slight humming sound. This is quite normal. Any other grinding, clicking or scraping noises are abnormal and must be investigated.

Good rotor balance is very important for long and reliable operation. The wind turbine must not be allowed to continue in operation if any unbalance is observed. The most common symptom of imbalance is observed when the turbine swings slightly from side to side as it speeds up. The swinging action will be worse at a particular rotor speed and may well disappear at higher speeds.

The rotor blades can suffer chips and erosion, mainly on their leading edge. Small chips can be repaired with glass fibre filling compound. All cracks must be carefully examined. Surface cracks can be repaired but any structural cracks must render the blade inoperative. If there is any doubt, the blade set must be replaced for safety. All blade damage can allow water to enter. This will cause the blade set to become unbalanced which will cause other mechanical failures and shortened bearing life.

9.3 OTHER DETAILS

PRODUCT CHANGES

Specifications may change due to continuous development. Kestrel Wind Turbines reserves the right to make design changes, improvements or additions to its products without obligation to install such changes or improvements in existing products.

WARRANTY AGREEMENT

Kestrel's wind turbines are manufactured to the highest standards, in accordance with Kestrel Wind Turbines' standard and quality specifications, and warrants that the wind turbine is in good working order upon delivery and for a period of 24 months. Warranty terms and conditions are outlined below.

1. Eveready warrants that Turbines will, on delivery, be free of defects in design, material and workmanship and will be fit for their intended purpose for a period of two years calculated from the date of installation, subject to proper installation, maintenance and use in accordance with the User Manual.
2. This warranty is further subject to the Customer returning the defective Turbine at its cost to the premises of Eveready within the warranty period and furnishing full details in writing of the alleged defect.
3. Eveready's obligations under this warranty shall be limited to the repair or replacement of defective Turbines at its cost or to a refund to the Customer of the original cost thereof, as Eveready may determine in its discretion. Eveready shall not be responsible for any damages suffered by the Customer pursuant to any defects covered by this warranty.
4. This warranty shall not apply to any damage to Turbines caused by winds exceeding 160 kilometres per hour or any other factors beyond the control of Eveready.
5. The Customer may purchase an extended warranty from Eveready in respect of Turbines, subject to Eveready's standard conditions.

CONTACT KESTREL WIND TURBINES

Kestrel Wind Turbines

Eveready Diversified Products (Pty) Ltd

Eveready Road

Struandale

North End

Port Elizabeth

South Africa

P.O. Box 3191

North End

Port Elizabeth

6056

Eastern Cape

Republic of South Africa

Tel: +27 (0)41 401 2500

Email: kestrelwind@eveready.co.za

Registration Number 2006/005438/07

VAT Registration Number 4870231406

Web: www.kestrelwind.co.za

10 CUSTOMER FEEDBACK



Customer enquiry and feedback sheet

Customer Information

Customer Name: _____

Postal Address: _____

Turbine Number: _____

Phone Number: _____

E-Mail Address: _____

Fax Number: _____

Enquiry Details

Complete the form and submit to Kestrel Wind Turbines. Your feedback and queries are valuable to us.

Indicate your enquiry or feedback in the space provided below

For OFFICIAL Use Only

Date Replied: _____

Signature: _____

Comments: _____

